

VENT RELIEF VALVE
1/8" - 1" NPT
.5 - 150 Psig (0.03 – 10.3 bar)

VRV

SERIES

Description

A compact, highly accurate, direct acting pressure relief valve. Factory preset to desired crack pressure and/or flow specifications. Internal adjustment provides tamper proof safety against inadvertent pressure changes. Available vent to atmosphere or inline configurations in brass, aluminum and 316 stainless steel. Valves feature a Quad ring seal which provides for extreme accuracy and repeatability with a narrow reseal band. Optional deflector cap increases flow capacity and provides for deflection of discharge.

Features

- Accurate and Repeatable Cracking Pressure
- 100% Factory Preset and Tested
- Zero Leakage to 95-98% of Set Pressure
- Tamper Proof Adjustment
- Excellent Reseal Performance
- Compact Size

Technical Data

- Set Pressure Range: 0.5 to 150 Psig (0.03 to 10.34 bar)
- Inline Valves (Series VRVI):
 Proof Pressure: 400 Psig (28 bar)
 Burst Pressure: >500 Psig (34 bar)
- Set Pressure Tolerance: Factory preset
 < 2 Psig (0.14 bar): +/-10%
 2 to 150 Psig (0.14 to 10.3 bar): +/- 5%
 (on increasing pressure)
- Reseal:
 80% of Set Pressure for valves specified 2-10 Psig
 (0.14 to 0.7 bar)
 92% of Set Pressure for valves specified 10-150
 Psig (0.7 to 10.3 bar)

Temperature Range: -320° to 400° F (-195° C to 205° C)

(based on sealing selection, see ordering information)



VRV
Vent to Atmosphere



VRVI
Inline

SERIES VRV VENT RELIEF VALVE

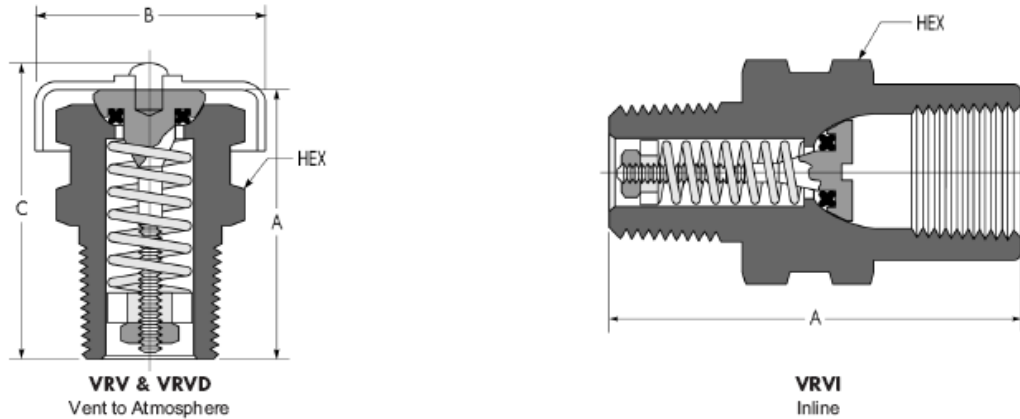

Dimensional Data

Pipe Size NPT ¹	VRV & VRVD				VRVI	
	A	B	C	Hex	A	Hex
1/8"	.97	.69	1.10	1/2"	Not Available	
1/4"	1.20	.92	1.32	5/8"	1.62	3/4"
3/8"	1.24	1.17	1.38	3/4"	2.12	7/8"
1/2"	1.75	1.40	1.92	1"	2.20	1"
3/4"	2.25	1.73	2.44	1-1/8"	2.72	1-1/4"
1"	3.12	1.94	3.29	1-1/2"	Not Available	

¹ Available with male straight thread connections. (SAE J1926, MS33656 with cone point removed) Consult factory

Materials of Construction

Component	Valve Body Material		
	Brass	Aluminum ¹	Stainless Steel
Valve Body	Brass, ASTM B16 (Nickel Plated, ASTM B689)	2024 Aluminum ASTM B211 (Clear Anodized, ASTM B580)	316 SS, ASTM A479
Stem	Brass, ASTM B16		
Spring Retainer ²			
Seal ³	As specified, see ordering information		
Spring	302 SS/17-7 PH, ASTM A313		
Locknut	18-8 SS		
Deflector Cap and Rivet	2024 Aluminum ASTM B211 (Clear Anodized, ASTM B580)		

¹ Available in 1/8" and 1/4" valves only

² All 1/8" and 1/4" valves have 316 stainless steel (ASTM A479) retainers

³ Lubricated with Krytox™

GENERANT

www.generant.com

1865 Route 23 South PO Box 768 Butler, New Jersey 07405 973.838.6500 Fax 973.838.4888

SERIES VRV VENT RELIEF VALVE

Flow Data, Series VRV (Vent to Atmosphere)

Nominal Spring		1		5		10		20		50		100		150	
Set Pressure Range		0.5 - 2.5		2.6 - 7.5		7.6 - 15		16 - 35		36-75		76 - 125		126 - 150	
Valve Size	Orifice	Flow (SCFH)	Kd	Flow (SCFH)	Kd	Flow (SCFH)	Kd	Flow (SCFH)	Kd	Flow (SCFH)	Kd	Flow (SCFH)	Kd	Flow (SCFH)	Kd
1/8" NPT (VRV-125)	0.187	7.7	0.03	34	0.06	55	0.07	90	0.08	260	0.12	500	0.13	610	0.11
1/4" NPT (VRV-250)	0.275	8	0.01	37	0.03	69	0.04	123	0.05	515	0.11	2011	0.24	2290	0.19
3/8" NPT (VRV-375)	0.345	12	0.01	58	0.03	108	0.04	150	0.04	550	0.07	1300	0.1	1140	0.06
1/2" NPT (VRV-500)	0.410	50	0.04	110	0.04	150	0.04	220	0.04	1458	0.14	3725	0.2	4000	0.15
3/4" NPT (VRV-750)	0.570	74	0.03	82	0.01	95	0.01	225	0.02	1050	0.05	2080	0.06	3450	0.07
1" NPT (VRV-1000)	0.785	Consult Factory		175	0.02	114	0.01	310	0.02	550	0.01	4600	0.07	5500	0.06

Flow Data, Series VRVD (Vent to Atmosphere, with Deflector Cap)

Nominal Spring		1		5		10		20		50		100		150	
Set Pressure Range		0.5 - 2.5		2.6 - 7.5		7.6 - 15		16 - 35		36-75		76 - 125		126 - 150	
Valve Size	Orifice	Flow (SCFH)	Kd	Flow (SCFH)	Kd	Flow (SCFH)	Kd	Flow (SCFH)	Kd	Flow (SCFH)	Kd	Flow (SCFH)	Kd	Flow (SCFH)	Kd
1/8" NPT (VRVD-125)	0.187	10.3	0.04	39	0.07	95	0.12	100	0.09	280	0.13	580	0.15	780	0.14
1/4" NPT (VRVD-250)	0.275	11	0.02	40	0.03	100	0.05	172	0.07	2340	0.5	4272	0.5	6650	0.55
3/8" NPT (VRVD-375)	0.345	13	0.01	77	0.04	130	0.05	195	0.05	738	0.1	4353	0.33	6275	0.33
1/2" NPT (VRVD-500)	0.410	60	0.05	246	0.09	420	0.11	658	0.12	2605	0.25	6800	0.37	7600	0.29
3/4" NPT (VRVD-750)	0.570	50	0.02	76	0.01	116	0.02	2500	0.23	6000	0.30	11000	0.30	20000+	0.34+
1" NPT (VRVD-1000)	0.785	Consult Factory		560	0.06	500	0.04	600	0.03	660	0.02	12000	0.18	20000+	0.20+

Flow Data, Series VRVI (Inline)

Nominal Spring		1		5		10		20		50		100		150	
Set Pressure Range		0.5 - 2.5		2.6 - 7.5		7.6 - 15		16 - 35		36-75		76 - 125		126 - 150	
Valve Size	Orifice	Flow (SCFH)	Kd	Flow (SCFH)	Kd	Flow (SCFH)	Kd	Flow (SCFH)	Kd	Flow (SCFH)	Kd	Flow (SCFH)	Kd	Flow (SCFH)	Kd
1/4" NPT (VRVI-250)	0.187	7.7	0.03	34	0.06	55	0.07	90	0.08	260	0.12	500	0.13	610	0.11
3/8" NPT (VRVI-375)	0.275	8	0.01	37	0.03	69	0.04	123	0.05	515	0.11	2011	0.24	2290	0.19
1/2" NPT (VRVI-500)	0.345	12	0.01	58	0.03	108	0.04	150	0.04	550	0.07	1300	0.1	1140	0.06
3/4" NPT (VRVI-750)	0.410	50	0.04	110	0.04	150	0.04	220	0.04	1458	0.14	3725	0.2	4000	0.15

Notes to Flow Data

- Flow and Kd (discharge coefficient) are stated at 110% accumulation above set point with Nitrogen and Zero Downstream Pressure
- Interpolate charts for set pressures between points given
- Restrictions in the inlet or outlet piping may reduce flow
- Exceeding 115% accumulation may result in valve failure
- Generant offers complete design assistance. Consult factory for correct relief valve sizing
- Individual flow curves available on request
- Orifice sizes are stated in inches



www.generant.com

1865 Route 23 South PO Box 768 Butler, New Jersey 07405 973.838.6500 Fax 973.838.4888

SERIES VRV VENT RELIEF VALVE

Ordering Information

VRV - 125 B - V - 15

SERIES

VRV - Vent to Atmosphere
VRVD - Vent to Atmosphere with Deflector Cap
VRVI - Inline Relief (Male x Female)

PORT SIZE

125 - 1/8"
250 - 1/4"
375 - 3/8"
500 - 1/2"
750 - 3/4"
1000 - 1" (Note: VRVI Not Available)
NPT threads per ANSI/ASME B1.20.1

Material Code

B - Brass
A - Aluminum
SS - 316 SS
For other materials, consult factory

NOMINAL SET PRESSURE

Specify .5 - 150 Psig
(Teflon™ Seals not available below 20 Psig)
Valves that are not actuated for a period of time may exhibit higher initial crack pressure (first bubble) than subsequent cycles

SEAL MATERIAL

V - Viton™, -20° F to 400° F (-29° C to 205° C)
B - Buna-N, -40° F to 250° F (-40° C to 121° C)
N - Neoprene, -40° F to 250° F (-40° C to 121° C)
EP - Ethylene Propylene, -65° F to 300° F (-54° C to 148° C)
FS - Fluorsilicone, -80° F to 350° F (-62° C to 176° C)
S - Silicone, -65° F to 400° F (-54° C to 205° C)
T - Teflon™, -320° F to 400° F (-220° C to 205° C)

OPTIONS

Oxygen cleaning, alternative seals and other thread configurations,
consult the factory

Viton, Krytox & Teflon are trademarks of DuPont.

PROPER COMPONENT SELECTION – When specifying a component, the total system design must be considered to ensure safe and trouble-free performance. Intended component function, materials compatibility, pressure ratings, installation, environment and maintenance are the responsibility of the system designer.



www.generant.com

1865 Route 23 South PO Box 768 Butler, New Jersey 07405 973.838.6500 Fax 973.838.4888