

TECHNICAL DATA

NOMINAL CRACK PRESSURES: .15, 1, 3, 5* & 8 PSIG
 MAX. OPERATING PRESSURE: 1000 PSIG @ 70° F.
 LEAKAGE IN CHECK DIRECTION (AMBIENT) :
 < 20 cc /MIN @ 25 PSI, NITROGEN
 EXTERNAL LEAKAGE: ZERO
 LUBRICANT: KRYTOX 205 ON COPPER CRUSH WASHER
 TEMPERATURE RANGE: -452° F TO 350° F.
 SUITABLE FOR LIQUID CRYOGENIC SERVICE

REVISIONS			
DCR	DESCRIPTION	DATE	REV.
1163	CONVERTED TO ACAD	9-16-2010	A
2093	UPDATED WITH ADDITIONAL SIZES	3/6/2013	B
2192	UPDATED DRAWING	6/21/2013	C
3508	UPDATED TEMPERATURE RANGE	2/6/2017	D



HOW TO ORDER

SERIES
 CV - CHECK VALVE

PIPE SIZE (NPT)
 253 - 1/4" NPT
 373 - 3/8" NPT
 503 - 1/2" NPT
 753 - 3/4" NPT
 1003 - 1" NPT
 1253 - 1 1/4" NPT
 1503 - 1 1/2" NPT
 2003 - 2" NPT

NOMINAL SET PRESSURE
 .15 - (0.1 - 0.4 PSIG)
 1 - (0.5 - 1 PSIG)
 3 - (2 - 4 PSIG)
 5* - (4 - 6 PSIG)
 8 - (6 - 10 PSIG)

* 5 PSI SPRING ONLY AVAILABLE ON 1/2" SIZE, CV-503

SEAL MATERIAL
 T - PTFE

MATERIAL CODE

B - BRASS
 S - 303 STAINLESS STEEL
 SS - 316 STAINLESS STEEL

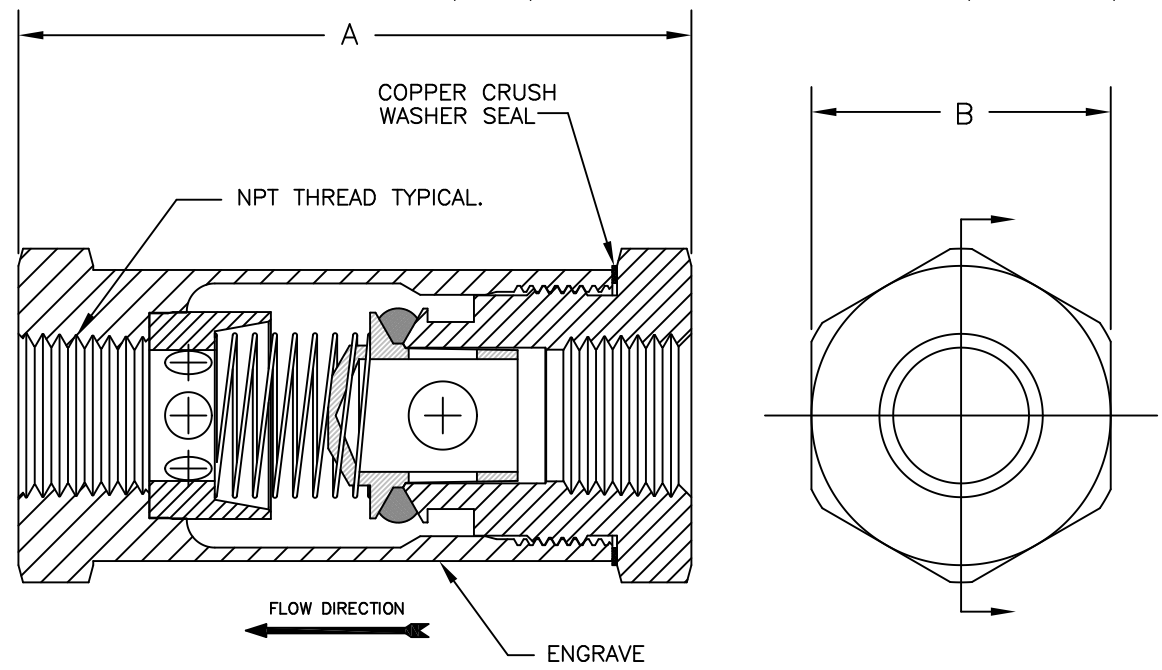

PIPE SIZE	THREAD	A (INCH)	B	Cv
253	1/4"-18 NPT	2.25	1"	3.0
373	3/8"-18 NPT	2.43	1 1/8"	3.9
503	1/2"-14 NPT	2.93	1 1/2"	7.4
753	3/4"-14 NPT	3.37	1 3/4"	11.4
1003	1"-11 1/2 NPT	3.99	2"	14.2
1253	1 1/4"-11 1/2 NPT	4.53	2 3/4"	26.8
1503	1 1/2"-11 1/2 NPT	5.29	2 3/4"	26.8
2003	2"-11 1/2 NPT	6.13	ø3 11/32"	51.0

- NOTES:
 1) CLEANED AND PACKAGED FOR OXYGEN SERVICE.
 2) NPT THREADS CONFORM TO ANSI/ASME STANDARD B1.20.1

THIS DOCUMENT CONTAINS INFORMATION THAT IS CONFIDENTIAL AND PROPRIETARY TO GENERANT CO. INC.. THIS DOCUMENT IS FURNISHED ON THE UNDERSTANDING THAT THE DOCUMENT AND INFORMATION IT CONTAINS WILL NOT BE COPIED OR DISCLOSED TO OTHERS EXCEPT WITH THE WRITTEN CONSENT OF GENERANT. IT WILL NOT BE USED FOR ANY PURPOSE OTHER THAN CONDUCTING BUSINESS WITH GENERANT, AND WILL BE RETURNED AND ALL FURTHER USE DISCONTINUED UPON REQUEST BY GENERANT.

MAT'L. AS SPECIFIED TOLERANCE SCHEDULE UNLESS OTHERWISE SPECIFIED FRACTIONAL: ± 1/64" ANGLES: ± 1/2" XX ± 1/16" XXX ± .005 CONCENTRICITY: .005 T.I.R. FINISHED SURFACES: 63 Ra BREAK CORNERS/EDGES: .016 MAX.	APPROVALS DRAWN H.H. PROD. M.G. ENG. B.B. MFG. M.G. Q.A. C.G.			TITLE: CRYOGENIC LIQUID SERVICE CHECK VALVE
	SIZE: A DATE: 9-16-10 DWG. NO.: CV-**3*-T-* SCALE: 1.5:1	REV. D	SHEET: 1 OF 1	