

**GDR
GDR
GDR
SERIES**

Description

The GDR Series Regulator provides reliable and precise pressure control in the most demanding applications. Optimized spring design with unique venturi design assures high flow with extremely low droop characteristics. Solid, non-tied diaphragm and all brass construction will provide leak-free and long-lasting performance. Regulator is fully balanced to virtually eliminate outlet pressure fluctuations due to inlet pressure variations. All GDR Series regulators are 100% factory tested.

Features

- **FULLY BALANCED DESIGN:** Maintains a constant delivery pressure regardless of inlet pressure fluctuations.
- **OPTIMIZED FOR HIGH FLOW:** Unique Venturi Tube and Optimized Spring Design allows for high flow rates.
- **WIDE PRESSURE RANGE:** Inlet Pressures up to 580 PSI, Outlet Pressures up to 450 PSI.
- **SOLID, NON-TIED, DIAPHRAGM:** Solid diaphragm eliminates potential leak path and increases sensitivity.
- **CONFIGURABLE:** Order Regulators with Various Porting Options, Panel-Mounted, with Chamber Pipe-A-Way, or Pilot Operated.
- **OXYGEN SERVICE COMPATIBLE:** Designed for use in Oxygen Service and Cleaned for use in O2 Service standard.
- **PED COMPLIANT:** SEP Declaration available (2014/68/EU Art. 4, ¶ 3)

Technical Data

GDR-500

Max Inlet Pressure: 580 PSIG (40 bar)

Outlet Pressure Ranges:

Spring	Outlet Pressure Range
A	0-55 PSIG (0-3.8 bar)
B	50-135 PSIG (3.5-9.3 bar)
C	125-225 PSIG (8.6-15.5 bar)
D	225-450* PSIG (15.5-31 bar)

*rated at 450 PSIG @ 100°F

A, B, and C Range Springs are interchangeable.

D Range Spring requires dedicated Chamber.

Fail Open Flow Coefficients:

Port Configuration	Fail Open Cv
1/4" NPT and BSPT	1.6
3/8" NPT	2.4
1/2" NPT and BSPT	2.9

GDR-500 Pilot Operated

Max. Pilot: 450 PSIG (31.0 bar) @ 100°F

Max. Usable Cv: 1.5

Pilot Pressure to Outlet Pressure: 1/.95
(100 PSI Pilot = 95 PSI Outlet)

GDR-1000

Max Inlet Pressure: 580 PSIG (40 bar)

Outlet Pressure Ranges:

Spring	Outlet Pressure Range
A	0-55 PSIG (0-3.8 bar)
B	50-135 PSIG (3.5-9.3 bar)
C	125-225 PSIG (8.6-15.5 bar)

A, B, and C Range Springs are interchangeable.

Fail Open Flow Coefficients:

Port Configuration	Fail Open Cv
3/4" and 1" NPT	5.8
3/4" and 1" BSPT	5.8

GDR-1000 Pilot Operated

Max. Pilot: 250 PSIG (17.2 bar) @ 140°F

Max. Usable Cv: 2.7

Pilot Pressure to Outlet Pressure: 1/.90
(100 PSI Pilot = 90 PSI Outlet)

Effect of Inlet Pressure Variation on Set (Regulator Balance): < 0.25 PSI per 100 PSI

Materials of Construction

Component	Material
Body	CW617N Forged Brass, EN 12420
Adjustment Screw, Valve, Valve Stem, Spring Button, Spring Retainer, Venturi Tube	CDA 360 Brass, ASTM B16
Chamber Insert	303 SS, ASTM A276
Adjustment Springs	GDR-500: Music Wire, ASTM A228 GDR-1000: Chrome Silicon, ASTM A401
Valve Spring	302 SS, ASTM A313
Diaphragm	FKM or EPDM
Soft Seals (Valve and O'Rings)	FKM or EPDM
Trim (Flange Screws and Locknut)	18-8 Stainless Steel

NOTES: Regulators are assembled with Dupont Krytox® lubricant.



STANDARD



PILOT OPERATED



PANEL MOUNT



PIPE-A-WAY OPTION

GAS DELIVERY REGULATOR

Dimensional Data

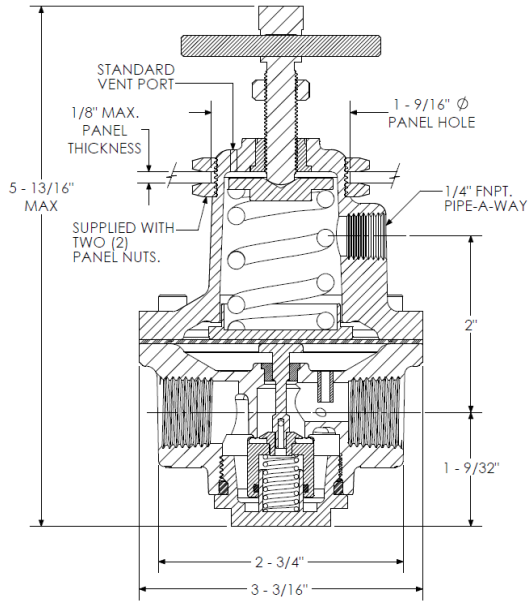

GDR-500
(shown with Panel Mount and Pipe-A-Way Options)

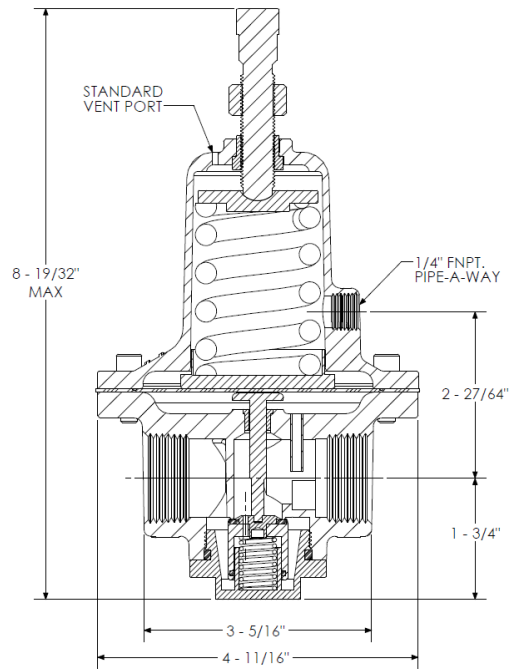

GDR-1000
(shown with Pipe-A-Way Option)

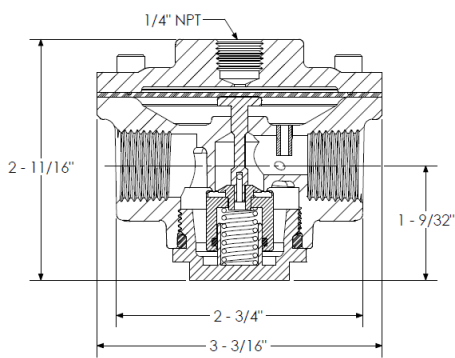

GDR-500 Pilot Operated

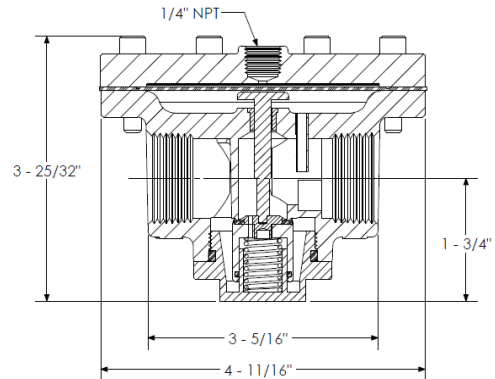

GDR-1000 Pilot Operated

Flow Performance

Each chart provides a variety of regulator setpoints and its respective flow performance with a constant inlet pressure condition. Flow Testing was performed using Nitrogen gas at ambient conditions. Use gas conversion factors listed on the next page to convert flow rates to a different gas service. Regulators were set in a dynamic condition at 60 SCFH N₂ flow.

GDR-500: A Spring

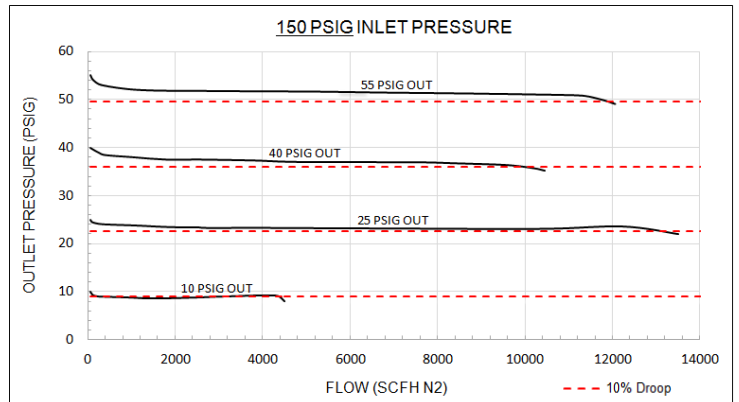
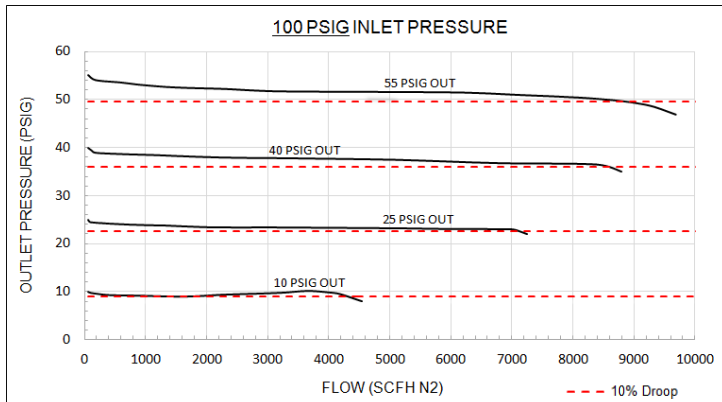

Flow Performance (continued)

GDR-500: B Spring

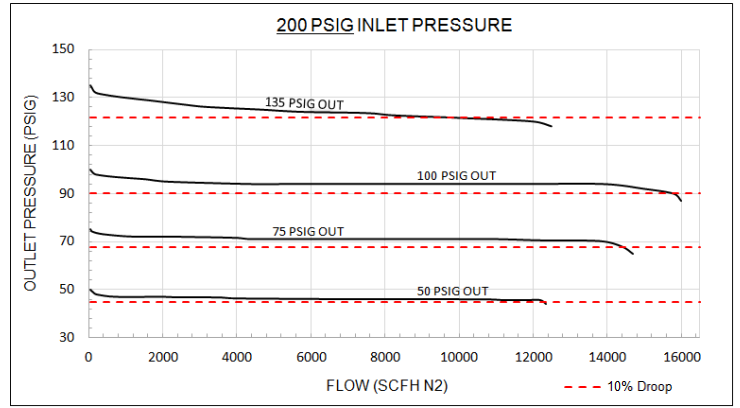
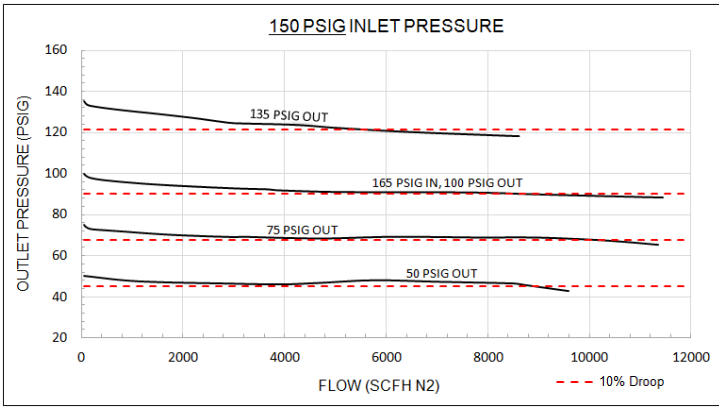

GDR-500: C Spring

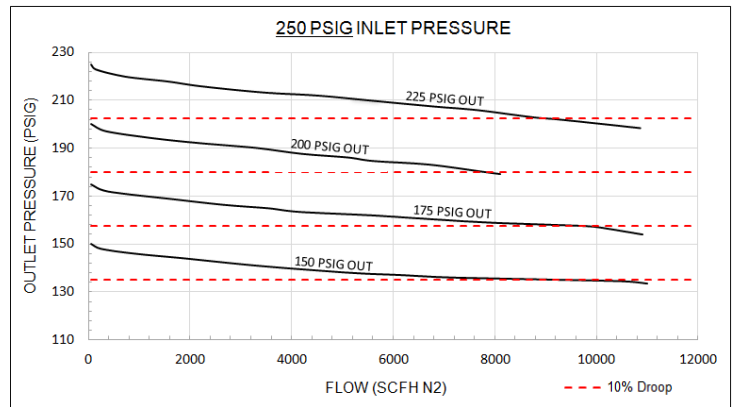
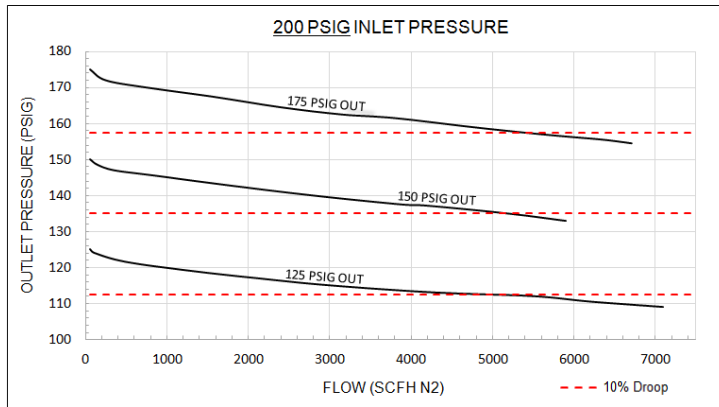

GDR-500: D Spring

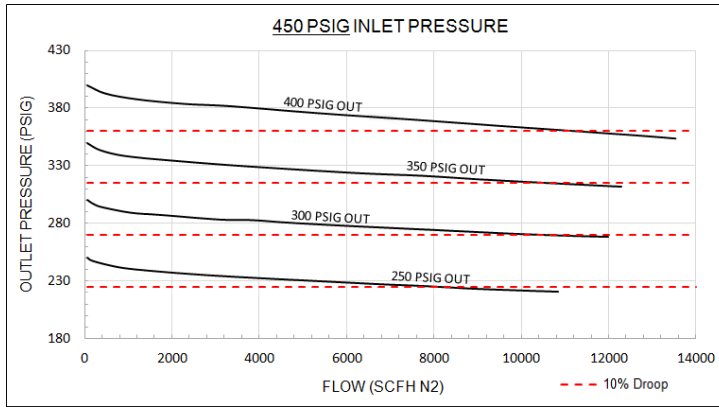

GAS CONVERSION FACTORS

Multiply Nitrogen Flow Rate by Conversion Factor to find equivalent gas flow rate.

Gas	Conversion Factor
Air	0.985
Argon	0.837
Carbon Dioxide	0.795
Helium	2.645
Hydrogen	3.603
Nitrogen	1.0
Nitrous Oxide	0.799
Natural Gas	1.285
Oxygen	0.935
Methane	1.320

GDR-1000: A Spring

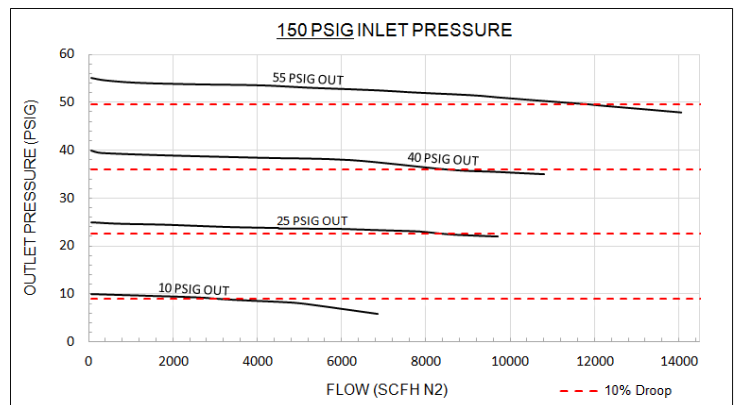
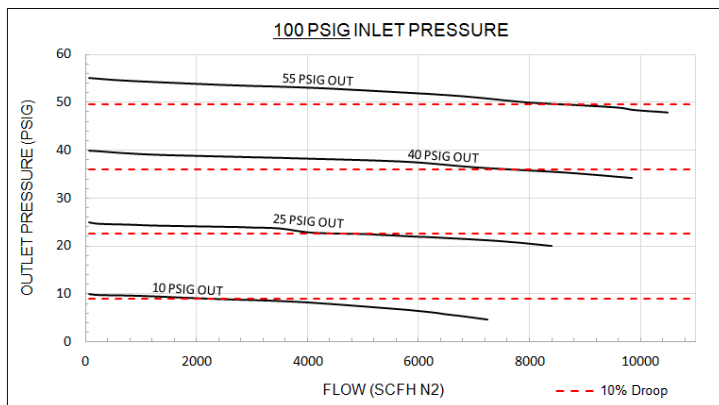

Flow Performance (continued)

GDR-1000: B Spring

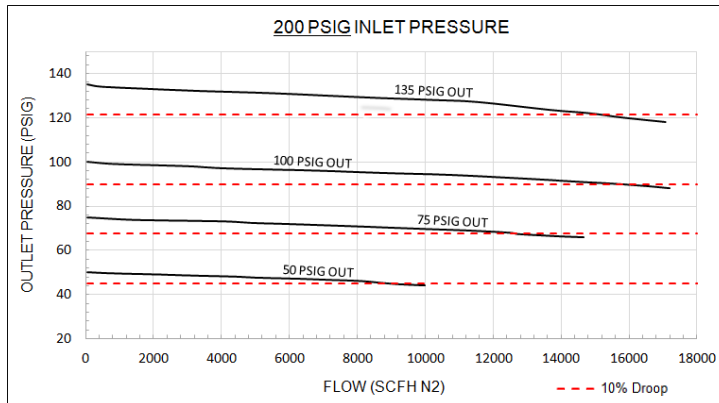
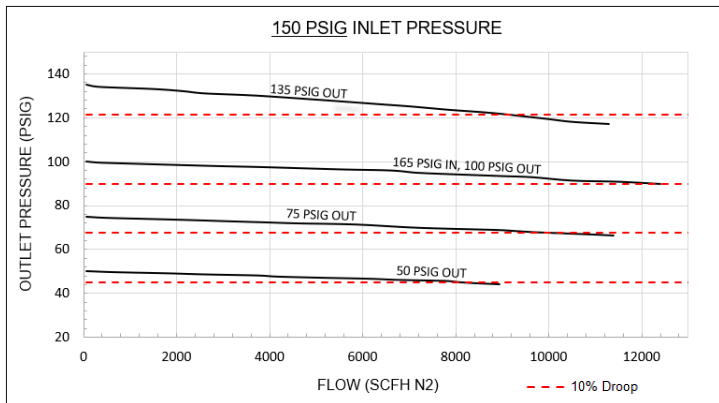

GDR-1000: C Spring

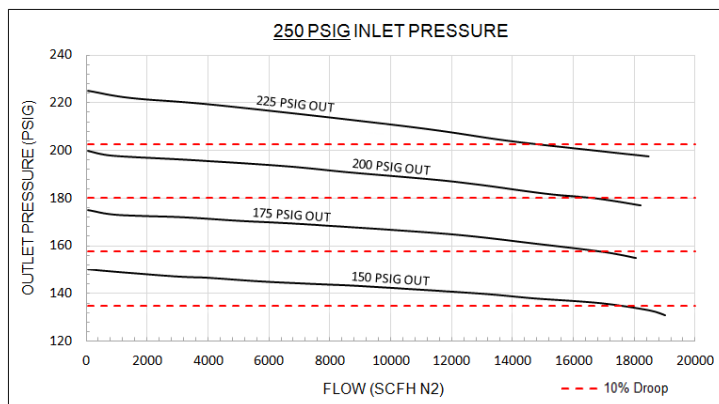
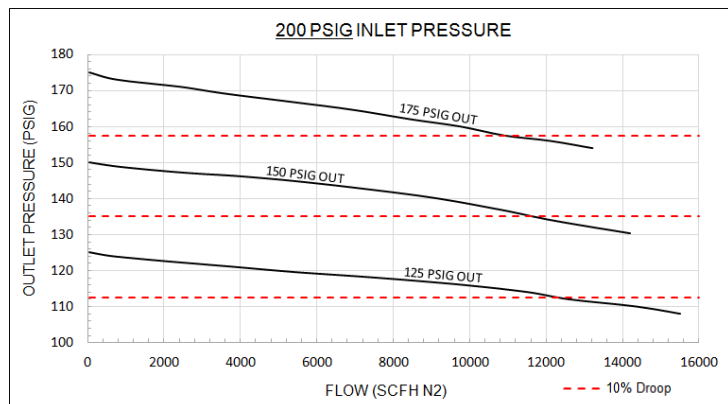

How To Order

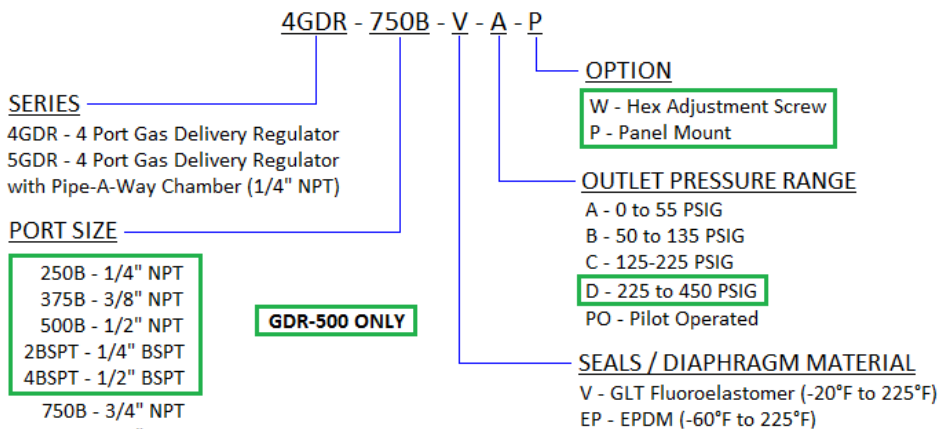

Note: All Regulators are supplied with 2 (two) 1/4" NPT Pipe Plugs. Pipe plugs are supplied finger tight. Final installation is the responsibility of the end user.

Compatibility Note: EP Seals are Recommended for CO2 Service.

Repair Kits

Includes: Valve Stem, Diaphragm, Valve Assembly, Valve Spring and Bottom Plug O-Ring

Model Size	Seal Material	Specify
1/4", 3/8" & 1/2"	FKM	GDR-RK-1V
	EPDM	GDR-RK-1EP
3/4" & 1"	FKM	GDR-RK-2V
	EPDM	GDR-RK-2EP

NOTE: All Repair Kits are cleaned for Oxygen Service.

Replacement Spring Kits

Includes: Spring (3/4" & 1" kit includes corresponding spring retainer)

Model Size	Specify
1/4", 3/8" & 1/2"	GDR-SK-1-*
3/4" & 1"	GDR-SK-2-*

*Specify Spring Model Code: A, B, C, or D

PROPER COMPONENT SELECTION – When specifying a component, the total system design must be considered to ensure safe and trouble-free performance. Intended component function, materials compatibility, pressure ratings, installation, environment and maintenance are the responsibility of the system designer.



www.generant.com

1865 Route 23 South PO Box 768 Butler, New Jersey 07405 973.838.6500 Fax 973.838.4888